

## VICTORIA

### *COMPETITION AND CONSUMER ACT 2010*

#### **Interim Ban Order**

I, the Honourable Michael O'Brien, Minister for Consumer Affairs, pursuant to section 109(1)(a)(i) of Schedule 2 to the *Competition and Consumer Act 2010*, applied as a law of Victoria by Part 2.2 of the *Australian Consumer and Fair Trading Act 2012*, impose an interim ban on the following consumer goods:

#### **Particulars of Consumer Goods**

Small, separable or loose permanent magnetic objects:

- (a) that are supplied as aggregated masses or in multiples of two or more; and
- (b) that are intended or marketed by the manufacturer primarily as a manipulative or construction desk toy or as jewellery; and
- (c) that have a magnetic flux index of greater than  $50 \text{ kG}^2\text{mm}^2$ ; and
- (d) where the product supplied contains more than one magnet that fits within the small parts cylinder specified in the International Standards Organization Toy Standard (ISO 8124-1:2009, *Safety of toys*).

#### **Hazard**

Small, powerful magnets can detach and be ingested. The ingested magnets may then attract each other and clamp parts of the digestive system together resulting in death or serious injury.

#### **Interpretation**

Measurement of the magnetic flux index ( $\text{KG}^2\text{mm}^2$ ) is calculated by multiplying the square of the maximum flux density ( $\text{KG}^2$ ) by the area of the pole surface of the magnet ( $\text{mm}^2$ ).

The small parts cylinder is a test apparatus taken from the Australian, International and other national toy standards (for example the International Standards Organization Toy Standard (ISO 8124-1:2009, *Safety of toys*) designed to identify parts which are small enough to pose an ingestion or inhalation hazard to children.

The test apparatus was developed on the basis of incidents of ingestion. It is well established, has been in these various standards for over 40 years (since toy standards were first developed) and is a measure well known and understood by industry. Measurements in the figure below are in mm

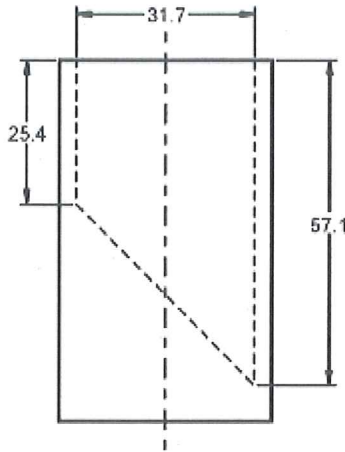

The effect of this Notice is to ban the supply of such consumer goods for a period of 60 days. This Notice commences with immediate effect on 23 August 2012.

The ban does not apply to magnets supplied:

- \* as parts for manufacture into other goods or for the repair of other goods;
- \* for scientific research; or
- \* as industrial, medical or therapeutic goods.

The effect of this Notice is to ban the supply of such consumer goods for a period of 60 days. This Notice commences with immediate effect on 23 August 2012.

DATED this 23<sup>rd</sup> day of August 2012.

*Michael O'Brien*

**HON. MICHAEL O'BRIEN MP**  
Minister for Consumer Affairs