



Tech Bulletin:

Aura Pro Cervélo Custom Edition aerobars fitted to some 2013 Cervélo bicycles: issue with clamp fixing bolts

Dear customer,

Safety is our biggest priority. We have discovered that there may be a safety risk with the 3T Aura Pro Cervélo Custom Edition aerobars fitted to some 2013-model Cervélo bicycles. Bolts on these aerobars may be too short and come loose, causing the clamps that support the bar extensions to detach from the basebar.

To avoid any safety issue, please tell 3T if your bar is affected so we can supply you with replacement bolts. These are longer and, when properly fitted, ensure that the clamps cannot loosen off. This voluntary measure from 3T is a preventive safety procedure aimed at complying with our continuous commitment to safety. If your bike is affected, we strongly recommend you not to ride it until the correct, new bolts are fitted.

Which bars are affected?

Aura Pro Cervélo Custom Edition aerobars supplied to Cervélo and fitted to certain models of Cervélo bicycle sold from September 2012 and listed below. Bars on these bicycles have wider clamps than standard Aura Pro bars – this is shown in figure 1. Standard Aura Pro bars sold to aftermarket retail customers are not affected.

3TCYCLING SRL

Via Vittorio Veneto 25

24041 Brembate (Bg) - Italy

Tel. +39.035.4943451

Fax +39.035.4943962

info@3Tcycling.com

www.3Tcycling.com

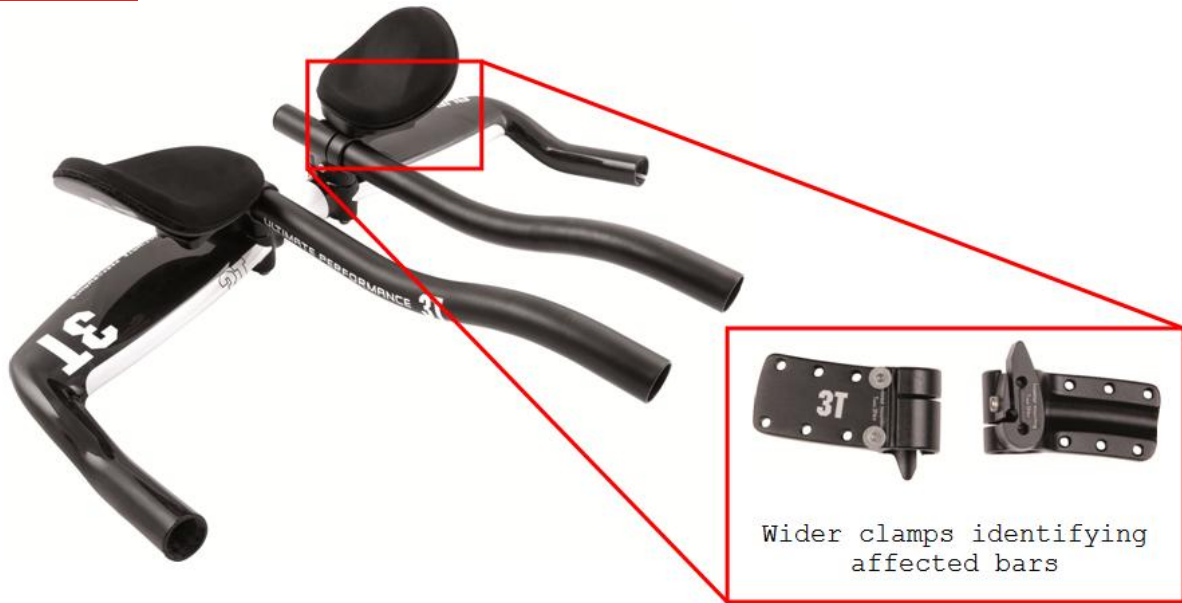

Figure 1: wider clamps on an Aura PRO aerobar

The affected bar with wider clamps has been assembled on Cervélo triathlon/time trial bikes, model year 2013 only. The models, available for sale only since September 2012, are:

- Cervélo P3 with Shimano Ultegra
- Cervélo P3 with Shimano Dura Ace
- Cervélo P5 with SRAM Red

What is the issue?

The bolts fixing the clamps may be too short for the increased overhang of the wider clamps and may not provide sufficient engagement to secure the clamp.

Bolts are shown in red, position 6, in figure 2 below.

3TCYCLING SRL

Via Vittorio Veneto 25
24041 Brembate (Bg) - Italy

Tel. +39.035.4943451
Fax +39.035.4943962

info@3Tcycling.com
www.3Tcycling.com

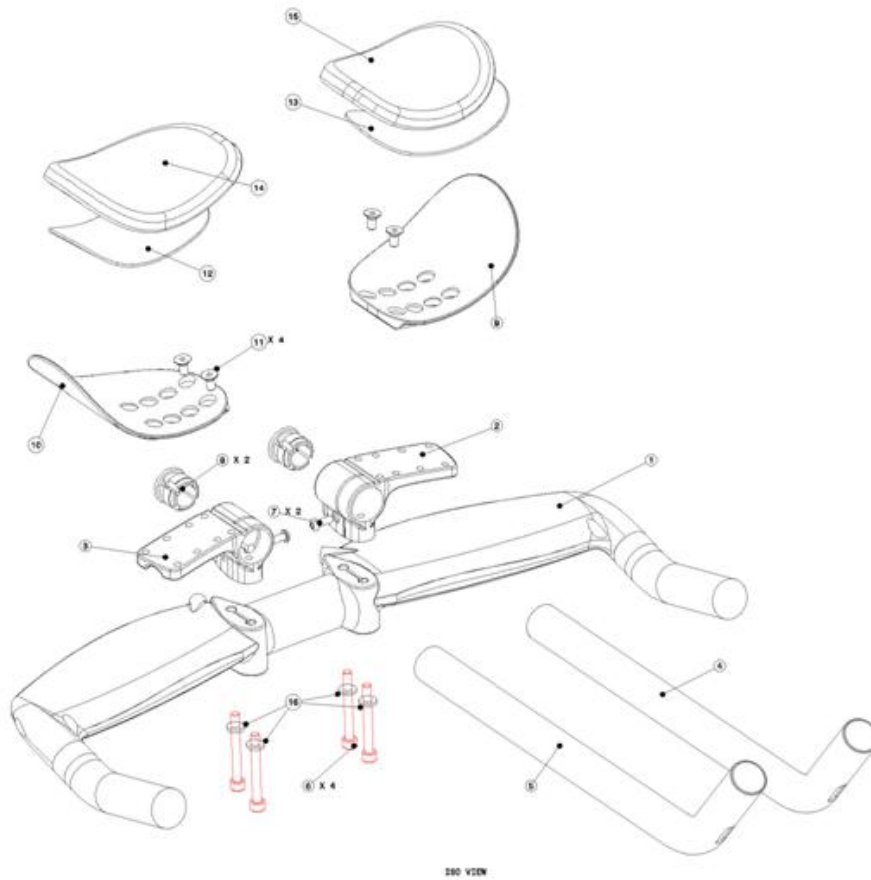

Figure 2: affected bolt on Aura PRO bar in Cervélo version

Affected bolts have been delivered in M5 x 35 mm DIN912 specification. New bolts are specified as M5 x 45 mm DIN912, in order to guarantee the highest safety standards available.

How to determine if your bar is affected?

We want to stress that this issue affects only bars delivered with a Cervélo bike that have the wider clamps shown in figure 1. If you are an owner of such a bike, please disassemble the affected bolts (as per Figure 2, position 6) and measure their length. If the bolts are less than 45 mm long (affected, wrong bolts are 35 mm), they must be replaced bolts with new, longer (45 mm) bolts.

Please note that in accordance with DIN912, the bolt length is defined as the actual shaft length without the head, shown in figure 3 below.

3TCYCLING SRL

Via Vittorio Veneto 25
24041 Brembate (Bg) - Italy

Tel. +39.035.4943451
Fax +39.035.4943962

info@3Tcycling.com
www.3Tcycling.com

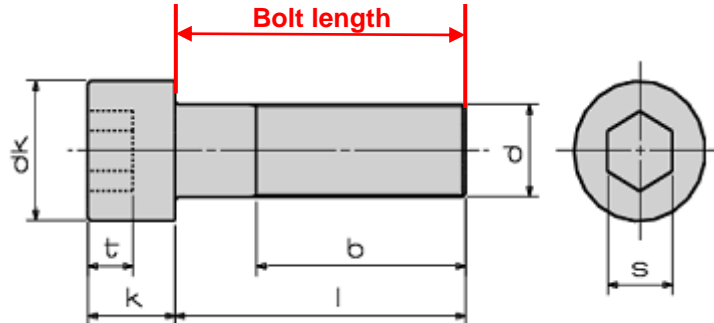

Figure 3: DIN912 bolt length definition

How to solve the issue?

There is no need to return the bike to your dealer or distributor to solve this issue. Simply replace the wrong bolts with new, longer bolts that 3T or our local distributor will send you, free of charge, to ensure you can ride safely with the minimum of downtime.

Please note that the maximum torque of these bolts is 5 Nm. Always use a calibrated torque wrench. If you are not confident you can successfully install the bolts, please have a qualified cycle mechanic carry this out.

The Technical Service of 3T Cycling Srl, European subsidiary of the 3T Group, will manage the worldwide replacement program.

Please contact 3T direct – service@3tcycling.com or +39 035 4943451 to get your package of replacement bolts. Alternatively, contact your local distributor. Further information will be soon available on www.3Tcycling.com.

3T apologizes in advance for any inconvenience this issue causes. We appreciate your understanding and we are looking forward to getting you back on your bike as possible.

3TCYCLING SRL

Via Vittorio Veneto 25
24041 Brembate (Bg) - Italy

Tel. +39.035.4943451
Fax +39.035.4943962

info@3Tcycling.com
www.3Tcycling.com