



POLARIS®

TECHNICAL SERVICE BULLETIN

Date: April 19, 2016

RZR

Bulletin Number: Z-16-01-AA

Model Years: 2014-2016

Safety Bulletin

Service Bulletin

Service Alert Fax

Distribution: Owner/Principle Service Manager Sales Manager Parts Manager Technicians

This Service Bulletin is located at www.polarisdealers.com

-Confidential and Proprietary-

***** THIS BULLETIN SUPERSEDES Z-15-03 *****

*****THIS BULLETIN MUST BE PERFORMED EVEN IF Z-15-03 WAS PREVIOUSLY PERFORMED*****

**SUBJECT: 2014-2016 RZR XP / XP 4 1000 and 2015-2016 RZR 900 / S 1000
FUEL TANK VENT LINE REPLACEMENT**

PURPOSE:

Some 2014-2016 RZR XP / XP 4 1000 and 2015-2016 RZR 900 / S 1000 models may have been manufactured with:

- An improperly routed fuel tank vent line may have insufficient clearance to the exhaust head pipe. A vent line with insufficient clearance to the exhaust head pipe may pose a fire hazard.
- An improperly routed fuel tank vent line which may cause the vent line to become kinked. A kinked vent line can cause the fuel tank to build pressure and expand. The expansion of the fuel tank may result in contact of the spinning prop shaft which may result in a fuel leak.

To address this issue, an improved fuel tank vent line should be installed and properly routed and restrained on the vehicle as described in the instructions below.

Refer to Unit Inquiry to determine what section of this bulletin applies to the vehicle being worked on. Please follow the repair instructions outlined in this Safety Bulletin.

AFFECTED MODELS:

Model Year	Model Numbers	Models	Vehicle Identification Number Range
2014	Z14ST1EAK / AM / AN / AW / AWL / FW/ FX	RZR XP 1000	Reference Unit Inquiry on the dealer website or the Service Bulletin list on the STOP site to lookup affected VINs.
	Z146T1EAM / AW	RZR XP 4 1000	
2015	Z15VAA87AC / AJ Z15VAE87AI / AK / AN / AS	RZR 900	
	Z15VAX87AL	RZR 900 XC	
	Z15VBA87AJ / LJ Z15VBE87AK / AL / AM / AT / AV / LT	RZR S 900	
	Z15VCE87AT / AV	RZR 4 900	
	Z15VDE99AO / AP / AT / AV / AW / AZ Z15VDK99AU	RZR XP 1000	
	Z15VDE99AL	RZR XP 1000 High Lifter	
	Z15VDE99FV / LP	RZR XP 1000 INT'L	
	Z15VFE99AP / AT / AV	RZR XP 4 1000	
2016	Z16VAA87A2 / Z16VAE87A9 / AL / AR / AU / AW	RZR 900	
	Z16VAX87AL / AM	RZR 900 XC	
	Z16VBA87A2 / AB / L2 Z16VBE87AB / AE / AR / AS / FR / LB / NR / JR	RZR S 900	
	Z16VCE87AB / AE / AR / AS	RZR 4 900	
	Z16VBE99AB / AK / AW	RZR S 1000	
	Z16VDE99AF / AM / AS / FM / LM / NM	RZR XP 1000	
	Z16VDM99AM	RZR XP 1000 High Lifter	
	Z16VFE99AF / AM / AS	RZR XP4 1000	
Z16VFM99AM	RZR XP4 1000 High Lifter		

CUSTOMER NOTIFICATION:

Dealers are required to review their sales records and make arrangements with customers for Safety Bulletin completion. In addition to consumer units, dealers are required to correct any affected units in their inventory. Polaris will be mailing a Safety Alert notification letter to consumers affected by this Safety Bulletin in the United States and Canada. Examples of the consumer letters can be found at the end of this Safety Bulletin.

WARRANTY CLAIM / PARTS INFORMATION:

A single group claim may be submitted listing the complete (17 digit) VIN for machines with the same model number. File claim type **SB (Service Bulletin)**. DO NOT PUT MORE THAN ONE MODEL NUMBER ON A CLAIM.

2014-2016 RZR XP 1000 / RZR XP 4 1000 non-High Lifter models	
SERVICE BULLETIN #	Z-16-01-AA
CLAIM TYPE	SB (Service Bulletin)
LABOR ALLOWANCE	0.5 Hr (0:30 minutes)
CLAIM PART NUMBERS	8450040-197 (QTY. 1) – Fuel Line 1/4" SAE #30R7 7170107 (QTY. 1) – Service Bulletin Completion Decal
PARTS AVAILABILITY	Dealers should review and approve the SMART order that was loaded for initial parts shipments

WARRANTY COVERAGE PERIOD:

Warranty coverage for Service Bulletin Z-16-01-A will begin on April 19, 2016. The bulletin has no expiration date.

PARTS RETURN OR DISPOSAL INFORMATION:

Dealers/Distributors: Under no circumstances shall the parts removed in this repair be re-used, sold, or re-purposed for another application. It is your dealership / distributor's responsibility to make sure every part replaced (related to this bulletin) is taken out of circulation and disposed of properly.

SERVICE BULLETIN COMPLETION DECAL:

A Service Bulletin Completion Decal must be completed for this bulletin repair. Remove the hood and place the decal on an easily visible portion of vehicle. If you require more decals, order them through normal Polaris parts ordering channels.

Sincerely,



Doug Koch
Technical Service and Warranty Manager

FUEL TANK VENT LINE INSPECTION / REPLACEMENT PROCEDURE (Z-16-01-AA):

This procedure is only applicable to 2014-2016 RZR XP 1000 / XP 4 1000 non-High Lifter models.

1. Loosen the fuel cap.
2. Mark the fuel tank vent line to determine original depth into frame.
 - 2014 and 2015 (early build) RZR XP 1000 / XP4 1000 – on cross member frame rail behind the airbox.
 - 2015 (late build) RZR XP 1000 / XP4 1000 – on the rear upper frame rail above the PVT

RZR XP 1000 / XP4 1000 (early build)

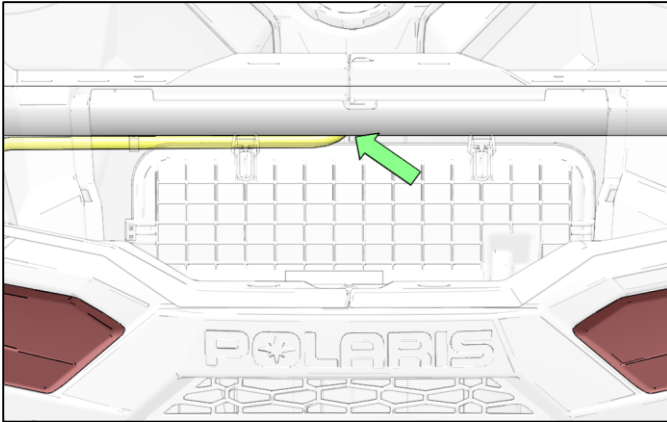

RZR XP 1000 / XP4 1000 (late build)

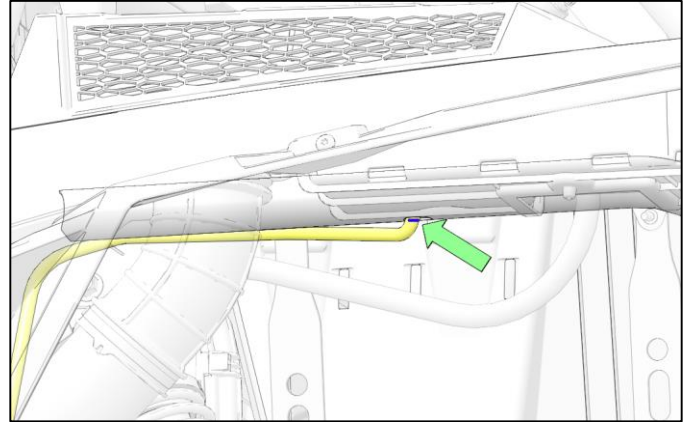

3. Remove the fuel vent line from frame.

NOTE: For 2014 and early build 2015 RZR 1000 models ONLY, remove the seats (rear seats for XP4 models) and two bolts (circled in red) retaining the upper air box and carefully pull the air box towards the rear of the vehicle for improved access to the vent line.

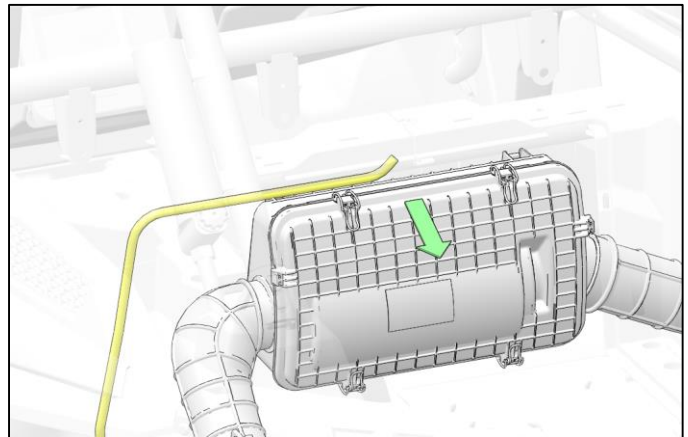
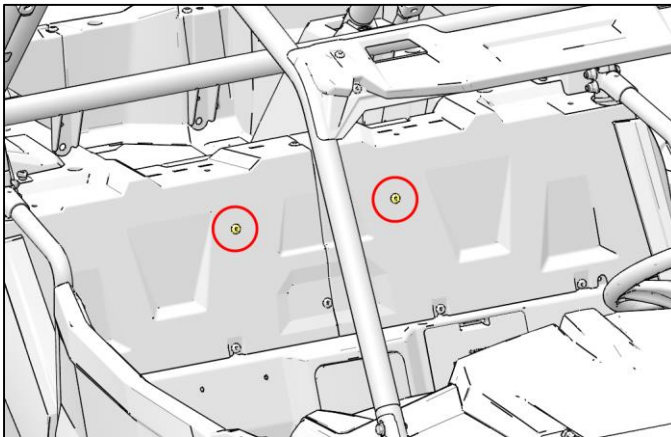

4. Attach a Mityvac® (p/n 2870975 available through Bosch) to the end of the fuel vent line.
5. Apply vacuum (approx. 5 pumps). The Mityvac should not build any vacuum in the fuel vent line and the gauge should quickly return to zero which indicates a clear, unobstructed vent line. Note that in a quiet environment a secondary indicator of a clear, unobstructed vent line is that while applying vacuum you may be able to hear the valve in the fuel tank cycling.
 - If no vacuum is built, proceed to step 8.
 - If vacuum is built, proceed to step 6.

Steps 6 and 7 are only required if the vent line fails the Mityvac test.

6. Remove the three rear skid plate fasteners ① to gain access to the prop shaft and fuel tank.
7. Inspect for damage due to the prop shaft ② rubbing into the fuel tank ③. *If there is damage from the prop shaft, take photos of the damaged vent line, the wear on the prop shaft, and the damage to the fuel tank. Start an Ask Polaris → Service and Warranty Question → Authorization: Non-Cosmetic & Polaris ESC case. Attach the photos to the case and for the CONCERN, CAUSE and CORRECTION enter "SB Z-16-01-AA". Use part number 2521436 as the primary failed part, enter the appropriate flat rate time, and submit the case to Polaris. You will still need to file the service bulletin claim once completed.* Continue to step 8.
8. Remove the seats for 2-seat models or the rear seats for XP4 models.
9. Disconnect the negative and positive battery cables from the battery. While holding a clean shop towel over the fuel line fitting, disconnect the fuel supply hose ④ and the fuel pump harness ⑤ from the fuel pump assembly.

CAUTION! There may be pressure in the fuel line if the key switch has recently been turned ON. Hold a rag over the fuel supply hose when disconnecting.

10. Reach under the fuel tank close off panel and disconnect the fuel tank vent line ⑥ from the tank breather fitting.
11. Remove the original fuel tank vent line by pulling the line out by the rear stabilizer bar mount.
12. Slide the new vent line through the opening for the fuel pump so the hose comes out near the rear stabilizer bar.

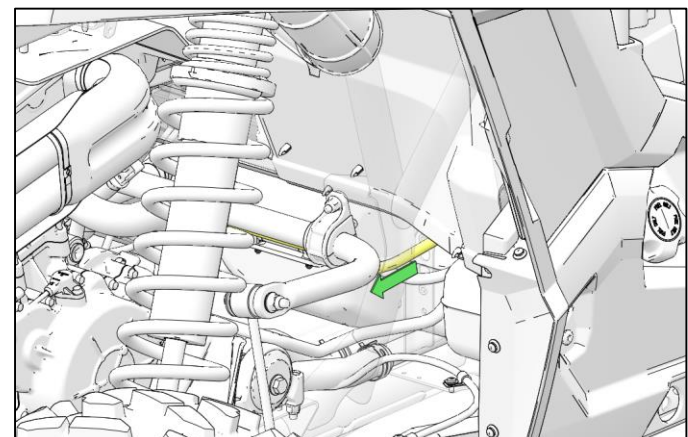
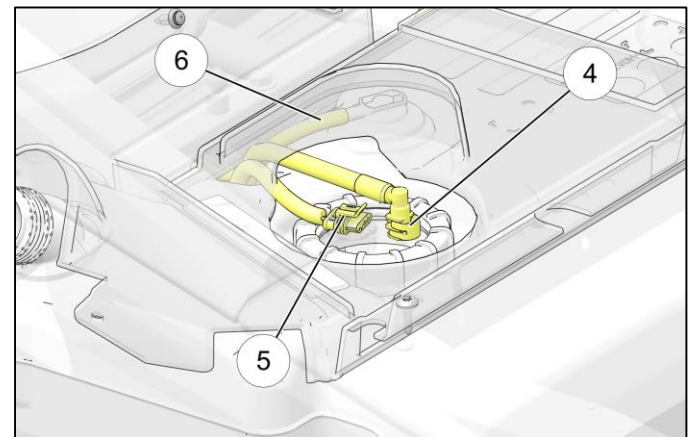
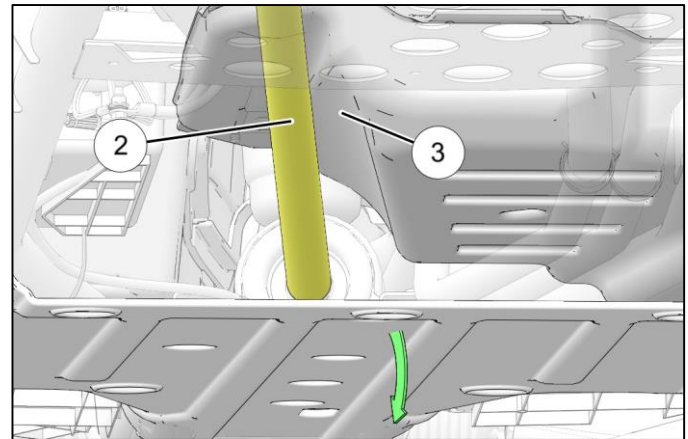
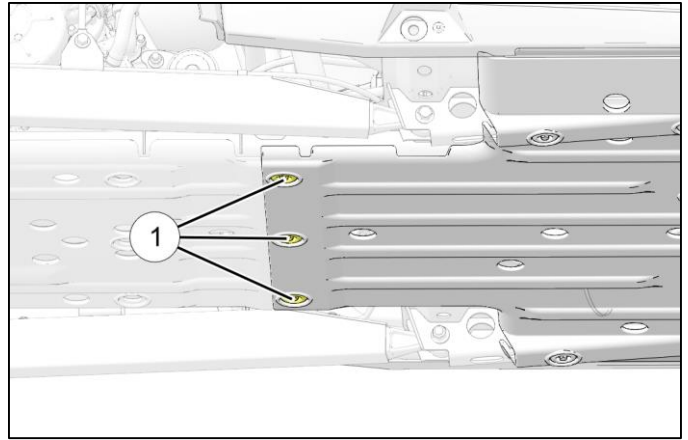

13. Slide the original vent line out of the zip ties (7) retaining the vent line and slide the new line through the zip ties.

NOTE: The vent hose fits loosely in the zip ties so they shouldn't need to be cut.

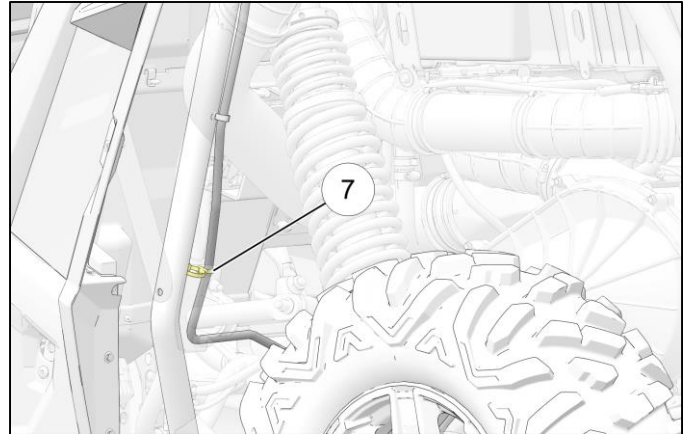
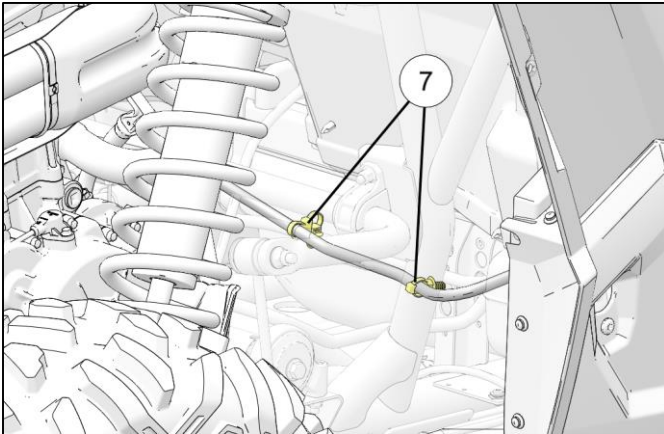

14. Open the line clips (8), located on the frame upright for the driver's side rear shock, and remove the vent line and install the new vent line and refasten the clips.

15. Using the original vent line routing as a guide, route the new vent line through the upper shock mount area. Use caution to avoid kinking the vent line during installation.

16. Install the new vent line onto the fuel tank fitting.

17. Connect the fuel supply hose and the fuel pump harness. Ensure the clip on the fuel supply hose clicks into place and lightly tug up on the hose to verify it is retained.

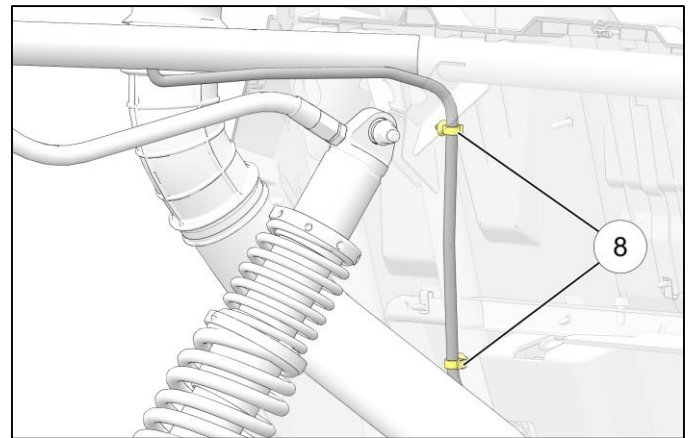

18. Using the old vent line as a reference, put a mark on the new vent line to indicate the depth the hose should go into the frame.

19. Attach a Mityvac to the end of the new vent line. Apply vacuum (approx. 5 pumps). The Mityvac should not build any vacuum in the fuel vent line (when applying vacuum, you can hear valve in tank cycling if vent line is not restricted). If vacuum is built, inspect the vent line for kinks. If no vacuum is built, **use engine oil or penetrating oil to lightly coat the outside surface of the vent line up to the mark of the original depth.** Insert the vent line into the frame tube starting at an angle less than 30° from parallel to the frame tube as shown..

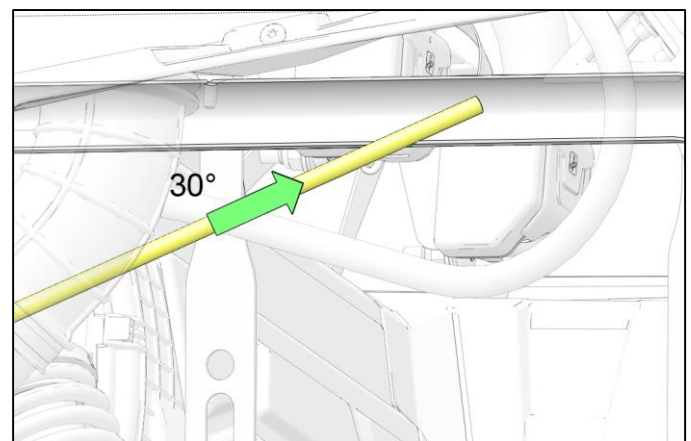

IMPORTANT: Inserting at this angle (or less) is critical to avoid risk of kinking the vent line during installation. Always apply engine oil or penetrating oil to the hose. Insert the hose to a depth slightly past the original mark.

20. Pull line back out slightly to ensure it's not kinked, and reinsert to original depth mark.

21. **Inspect the clearance between all vent lines and all exhaust components. A minimum of 6 inches (16 cm) of clearance must be maintained in all areas.**

22. Install / tighten the fuel cap.
23. Reconnect the battery and install the seats.
24. Install the three rear skid plate fasteners. Torque fasteners to specification.

TORQUE
Skid Plate Fasteners: 8 ft-lbs (11 Nm)

25. Turn the ignition switch to the ON position to verify there are no fuel leaks.
26. File bulletin Z-16-01-AA.

SAFETY RECALL NOTICE

PLEASE READ IMMEDIATELY

Dear Polaris *RZR* Owner,

In cooperation with the U.S. Consumer Product Safety Commission (CPSC), Polaris Industries Inc. has issued Safety Alert Z-16-01 for some Model Year 2014-2016 *RZR* vehicles.

The reason for this recall:

Your vehicle is affected by the conditions listed below, any of which may pose a fire hazard.

What Polaris and your dealer will do:

Polaris is working with suppliers to ensure parts will be available as soon as possible. Your Polaris *RZR* dealer has been authorized to complete the updates outlined below at no cost to you:

<u>Affected Component</u>	<u>Repair Action</u>
Z-16-01-A Fuel Tank Vent Line	Replace the fuel tank vent line to ensure proper routing and a more durable material that prevents kinking and abrasion. This must be completed in addition to a prior bulletin relating to a pinched vent line.

What you should do:

Please contact your local Polaris *RZR* dealer at your earliest convenience schedule an appointment to have the bulletin completed. When making contact with your dealer, discuss parts availability, their schedule and how long they will need to keep your vehicle to complete the updates.

DO NOT OPERATE YOUR VEHICLE UNTIL THIS SAFETY BULLETIN HAS BEEN COMPLETED BY YOUR POLARIS *RZR* DEALER.

This notice was mailed to you according to our most current registration information. If you no longer own this vehicle, or if some of the contact information in this notice is incorrect, please contact your local Polaris *RZR* dealer to complete a transfer of ownership.

While your Polaris *RZR* dealer is in the best position to answer your questions, if you have any questions your dealer cannot address, you may call our Customer Service Department at: 1-800-POLARIS (765-2747). If you need assistance contacting or locating a Polaris Dealer, please call 1-800-POLARIS or visit the Polaris web site at www.polaris.com.

We apologize for this inconvenience and assure you that we are committed to customer satisfaction and providing world class products for riders to enjoy.

Sincerely,

Polaris Off-Road Vehicles